

FD4D Parts List

Table of Contents

Cabinet

Condensing Unit

Evaporator

Auger Drive Motor

Bin Top

Water System

Control Box

Kits

Wiring Diagrams

FD4

THE PARTS ILLUSTRATIONS AND PARTS LISTS

GENERAL

This section contains the Parts Illustrations and the Parts List for each of the major assemblies in the Model FD4A-1D.

A *No Number* designation, when used in the Part Number Column indicates the unit is not available from SCOTSMAN as an assembly. This designation is used only for the convenience and clarity of division in cataloging.

HOW TO ORDER PARTS OR ASSEMBLIES

When ordering parts or assemblies, to avoid costly delays and errors in shipment, give the part number, the complete description shown in the list, and the quantities of each part or assembly required. Also include the model name, the serial number of the icemaker for which the part is required and for parts which require color matching, the color of the cabinet.

All part numbers have TEN DIGITS (spaces), required for use in the Computer System. BE SURE to fill in ALL SPACES in the CATALOG NUMBER column, on the parts order form.

Enter the QUANTITY of the parts ordered, in the last digit column under the QUANTITY column heading, the one under the small 55 number, for parts from 1 thru 9. For 10 or more parts use two columns.

To be sure you receive the proper parts in the proper quantities, ALWAYS use the PART NUMBERS and DESCRIPTIONS given in the Parts Manuals.

Write an order for the part. Use SCOTSMAN Parts Order Form (DN103). Be sure to include:

- Distributor Name.
- (Use for DROP-SHIP order ONLY.)
- Distributor Purchase Order Number.
- Carrier.
- How shipped (Truck, Rail, UPS, etc.)
- Date ordered.
- Part Catalog Number. (Use full TEN digits (spaces) listed in Parts Manual, including dashes between numbers.)
- Description - as listed in Parts Manual.
- Quantity - number of parts ordered. (Use far right column.)

WIRING DIAGRAMS

This section is provided as an aid in understanding the electrical circuitry of the flaker dispenser.

The wiring diagram in this Section is:
FD4A-1D 115/60/1

//////////////////// WARNING //////////////////////

When conducting a continuity check of the modular cuber:

1. Disconnect the main power source.
2. DO NOT use an incandescent lamp or jumper wire, conduct all tests with a volt-ohm-meter.

////////////////////////////////////

FD4 THE PARTS ILLUSTRATIONS AND PARTS LISTS

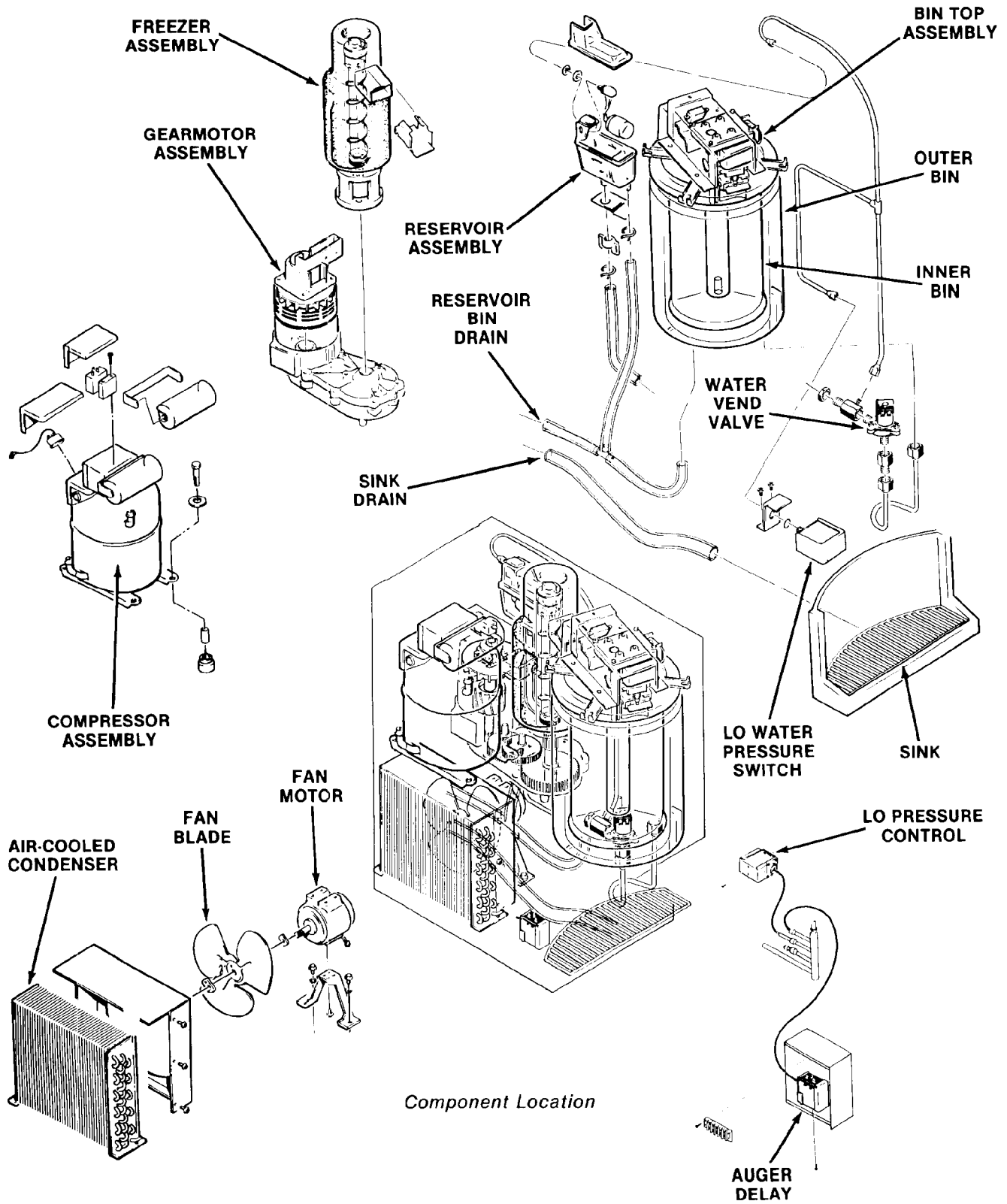

FD4

THE PARTS ILLUSTRATIONS AND PARTS LISTS

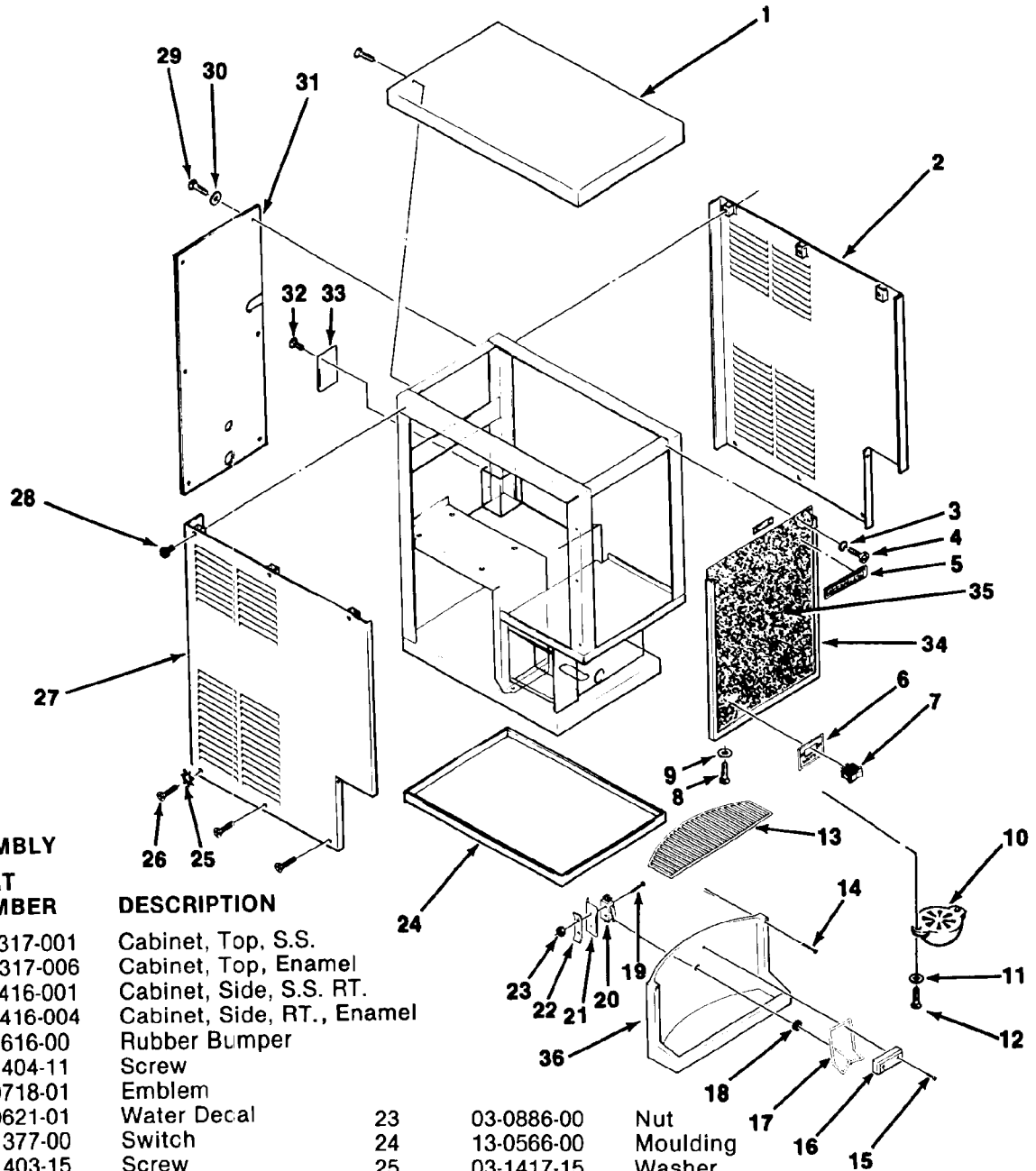

CABINET ASSEMBLY

ITEM NUMBER	PART NUMBER	DESCRIPTION
1	A16317-001	Cabinet, Top, S.S.
	A16317-006	Cabinet, Top, Enamel
2	A21416-001	Cabinet, Side, S.S. RT.
	A21416-004	Cabinet, Side, RT., Enamel
3	13-0616-00	Rubber Bumper
4	03-1404-11	Screw
5	15-0718-01	Emblem
6	15-0621-01	Water Decal
7	12-1377-00	Switch
8	03-1403-15	Screw
9	03-1417-03	Washer
10	02-1804-00	Spout Exterior
11	03-1407-03	Washer
12	03-1403-19	Screw
13	02-1473-00	Grate
14	03-1418-28	Screw
15	03-1418-29	Screw
16	02-1833-00	Adaptor
17	A21544-000	Actuator Arm
18	12-1213-04	Bushing
19	02-1403-09	Screw
20	12-1641-00	Switch
21	No Number	Insulation
22	03-1417-07	Washer
23	03-0886-00	Nut
24	13-0566-00	Moulding
25	03-1417-15	Washer
26	03-1418-05	Screw
27	A21415-004	Cabinet, Side LT., Enamel
	A21415-001	Cabinet, Side, S.S. LT.
28	03-1404-09	Screw
29	03-1404-09	Screw
30	03-1417-03	Washer
31	A21405-004	Back Panel, Enamel
	A21405-001	Back Panel, S.S.
32	03-1403-17	Screw
33	No Number	Junction Box Cover
34	15-0507-00	Molding Trim
35	A27500-001	Front Panel SS
	A27500-002	Front Panel, Vinyl Cork
36	A21429-000	Sink

FD4 THE PARTS ILLUSTRATIONS AND PARTS LISTS

MAJOR COMPONENTS

ITEM NUMBER	PART NUMBER	DESCRIPTION
1	18-2200-26	Relay
2	18-1901-33	Capacitor
3	03-1405-20	Screw
4	03-1407-07	Washer
5	18-2200-27	Mounting Sleeve
6	18-2200-28	Mounting Grommet
7	18-2200-01	Compressor
8	18-2200-25	Overload
9	12-1576-01	Fan Motor
10	02-0831-00	Drier
11	A20550-000	Shroud
12	18-1927-00	Condenser
13	03-1404-15	Screw
14	18-0137-01	Fan Blade
15	18-0422-00	Fan Bracket
16	03-0571-00	Screw
17	03-1417-09	Washer
18	03-1405-03	Screw
19	03-1417-09	Washer
20	18-2200-39	Start Capacitor BKT.
21	18-2200-38	Start Capacitor Cap
22	12-1573-01	Fan Motor Wire

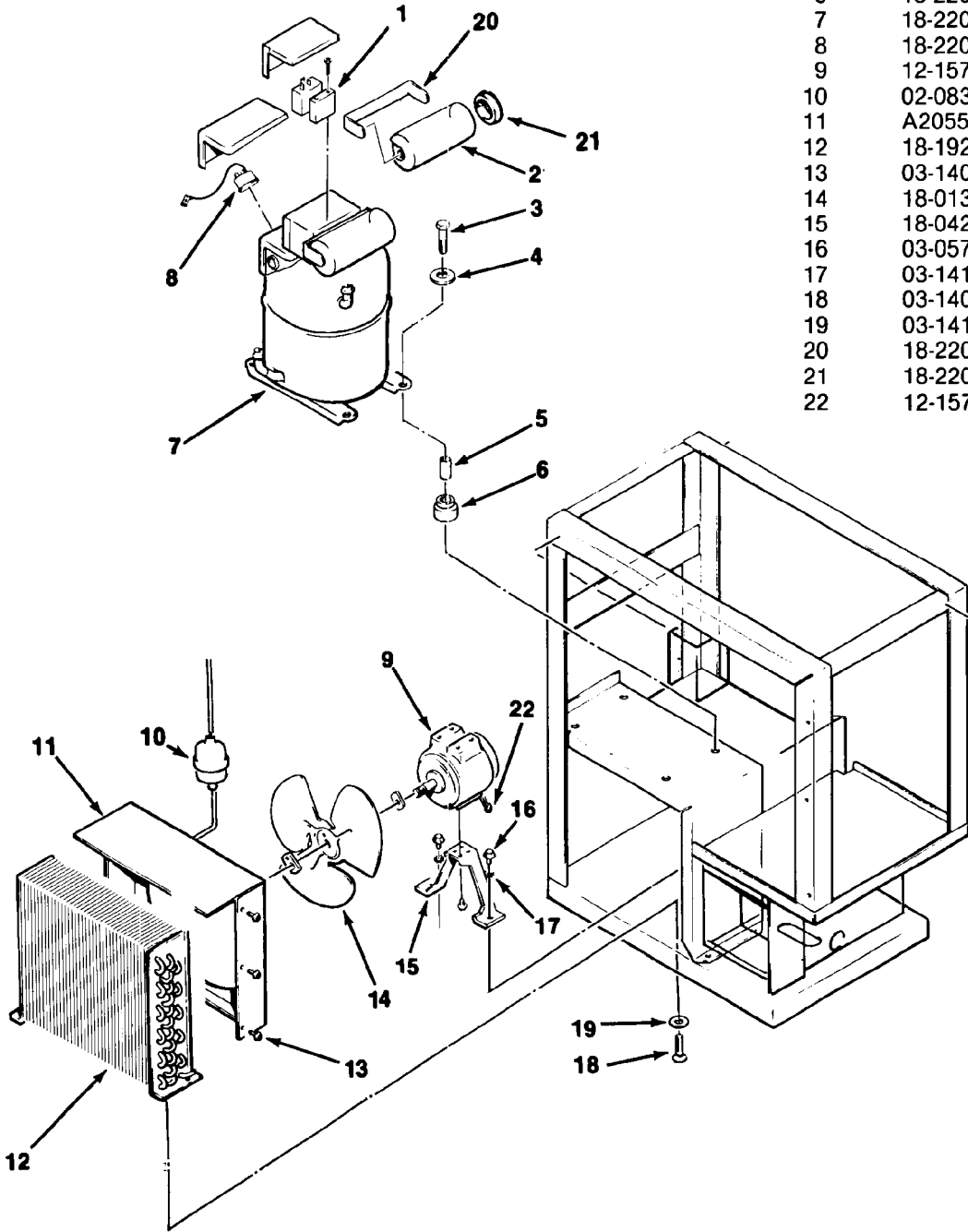

FD4 THE PARTS ILLUSTRATIONS AND PARTS LISTS

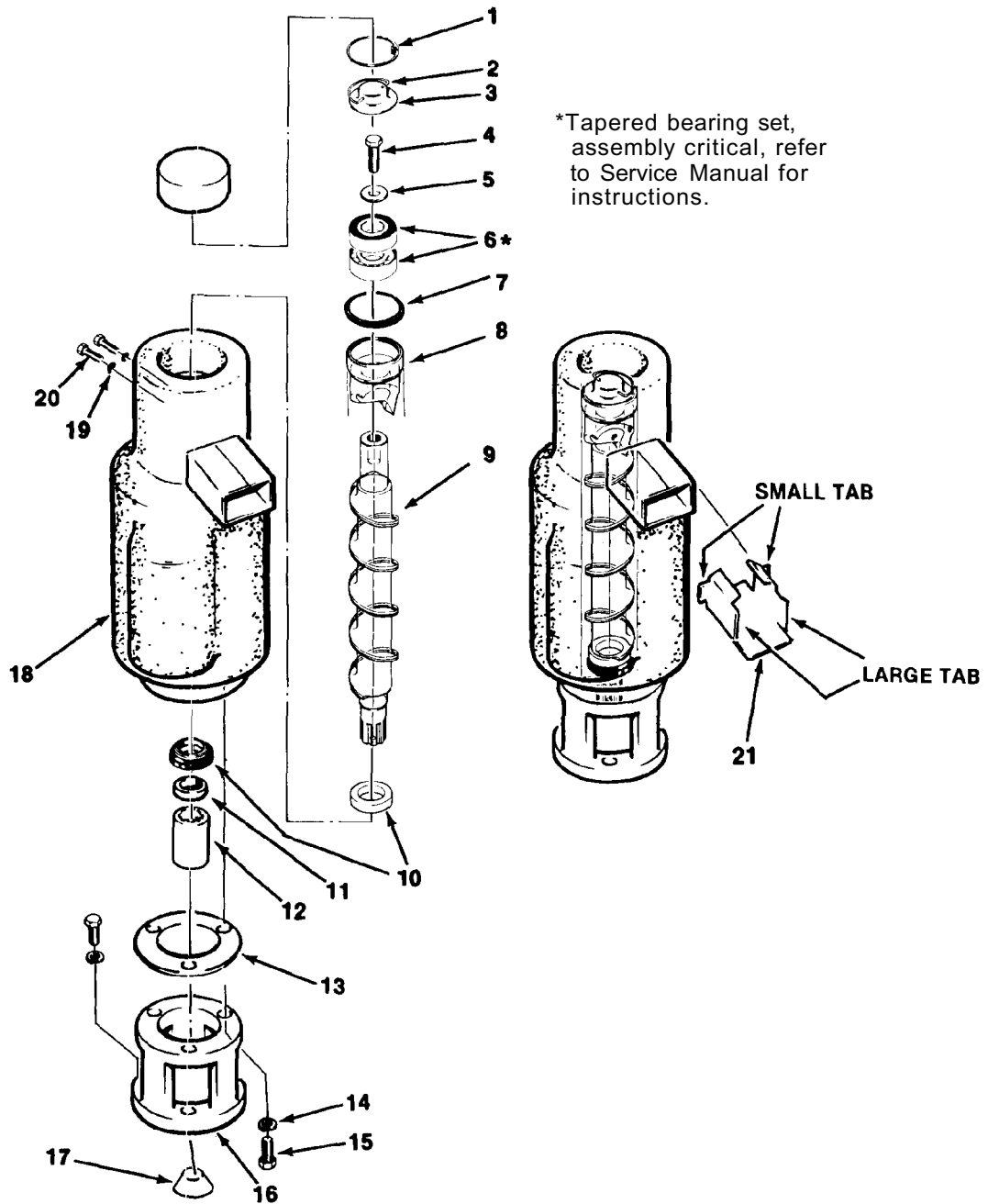

FREEZER ASSEMBLY

ITEM NUMBER	PART NUMBER	DESCRIPTION
1	03-1558-03	Retainer Ring
2	A08162-000	Cap Hook
3	A07701-000	Cap
4	03-0758-00	Screw
5	A07699-000	Washer
6	02-1412-20	Top Bearing, Matched Set
7	13-0617-16	"O" Ring
8	A14591-020	Breaker with Bearing Assembly, includes Items #6-7-8
9	02-4023-20	Auger
10	02-1300-01	Water Seal
11	02-0417-20	Bearing, Lower
12	A29915-002	Spline Drive Coupling
13	03-1505-00	Gasket
14	03-1410-04	Washer (3)
15	03-1420-01	Cap Screw (3)
16	08-0595-01	Adapter, Amaloy
17	13-0709-01	Shaft Drip Shield, Rubber
18	A26742-020	Evaporator Shell, includes suction line
19	03-1417-07	Washer
20	03-1403-46	Screw
21	A16151-000	Spout Extention

FD4 Service Parts

Gear Reducer and Motor

Item Number	Part Number	Description
1	A27494-001	Centrifugal switch kit
2	12-2059-01	Switch
3	A27494-001	Housing
4	03-1403-77	Screw
5	A30579-001	Shaft & actuator
6	03-1408-36	Washer
7	A38487-001	Motor housing
8	A28168-001	Cooling fan
9	no number	Part of item 10
10	A37707-021	60 Hz motor kit*
11	03-1408-08	Washer
12	02-1501-00	Bearing
13	02-3969-20	Grease seal (input)
14	02-1503-00	Grease seal (output)
15	A28165-021	Gear case cover
16	03-1408-21	Washer
17	03-1408-04	Washer
18	02-2445-01	Output shaft
19	03-1515-03	Retaining ring
20	03-1602-01	Woodruff key

* includes items 7, 8, 9, 10, 11 and 12

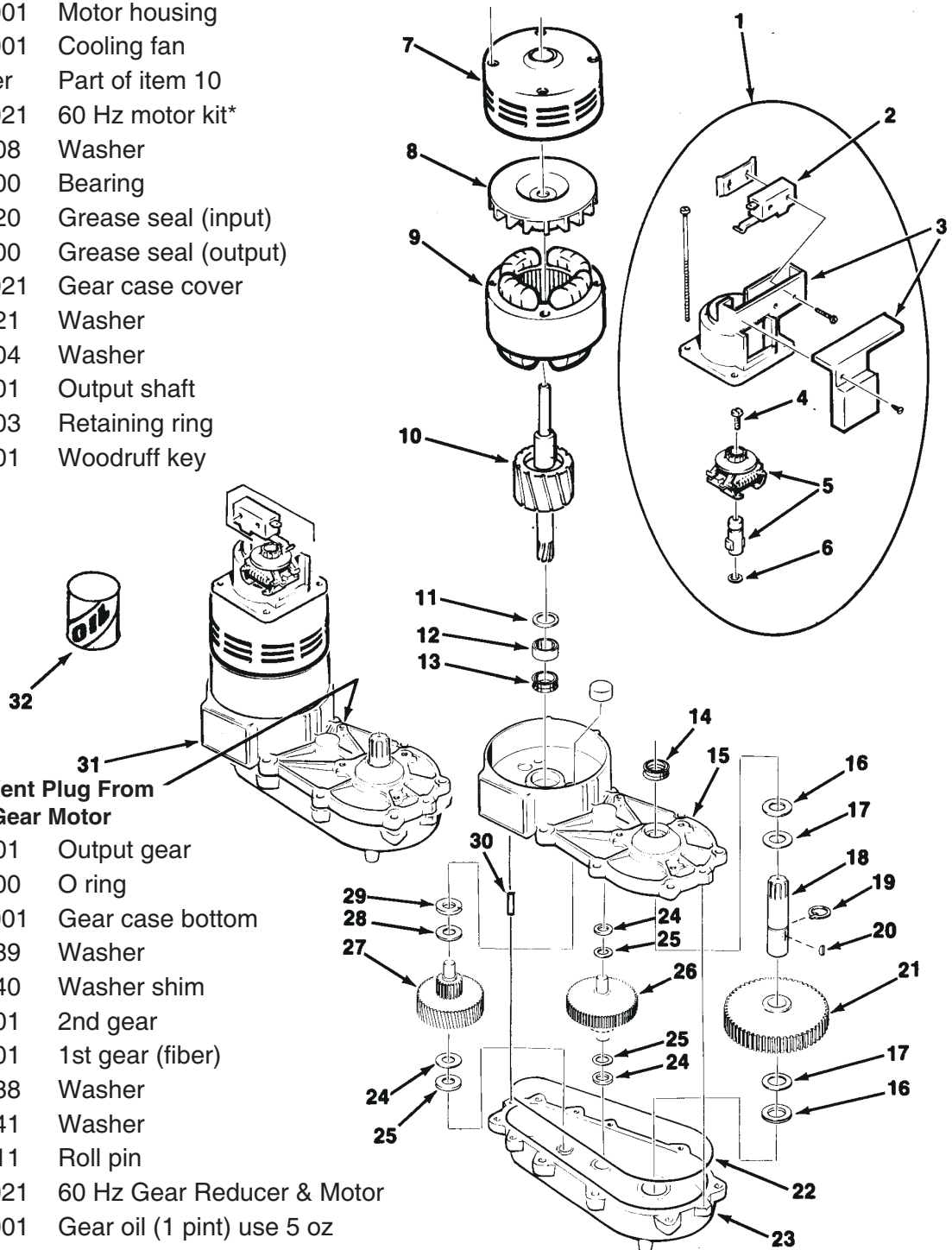

Remove Rubber Vent Plug From Replacement Gear Motor

21	02-2444-01	Output gear
22	02-1505-00	O ring
23	A28166-001	Gear case bottom
24	03-1408-39	Washer
25	03-1408-40	Washer shim
26	02-2439-01	2nd gear
27	02-2438-01	1st gear (fiber)
28	03-1408-38	Washer
29	03-1408-41	Washer
30	03-0774-11	Roll pin
31	A31977-021	60 Hz Gear Reducer & Motor
32	A25835-001	Gear oil (1 pint) use 5 oz

FD4 THE PARTS ILLUSTRATIONS AND PARTS LISTS

BIN TOP ASSEMBLY

ITEM NUMBER	PART NUMBER	DESCRIPTION
1	03-1403-16	Screw
2	03-1417-05	Washer
3	No Number	Cover Switch
4	12-1610-01	Motor
5	12-1213-05	Bushing
6	03-1404-08	Screw
7	No Number	Cover, Switch
8	19-0569-01	Lubricant, Food Grade
9	A21207-000	Shaft
10	No Number	Strain Bushing
11	03-1417-09	Washer
12	03-1403-47	Screw
13	No Number	Cover Switch, Front
14	03-1404-08	Screw
15	A16104-000	Pin Hinge
16	A16010-000	Lever, Ice Contact
17	12-1018-01	Switch
18	A16098-000	Bin, Top Fab Assembly
19	A19269-000	Bin, Ice Control Assembly
20	03-1417-20	Lockwasher
21	03-0255-02	Wing Nut
22	A27491-001	Bin, Top Assembly Complete
23	A16495-000	Nut - Ice Bracket

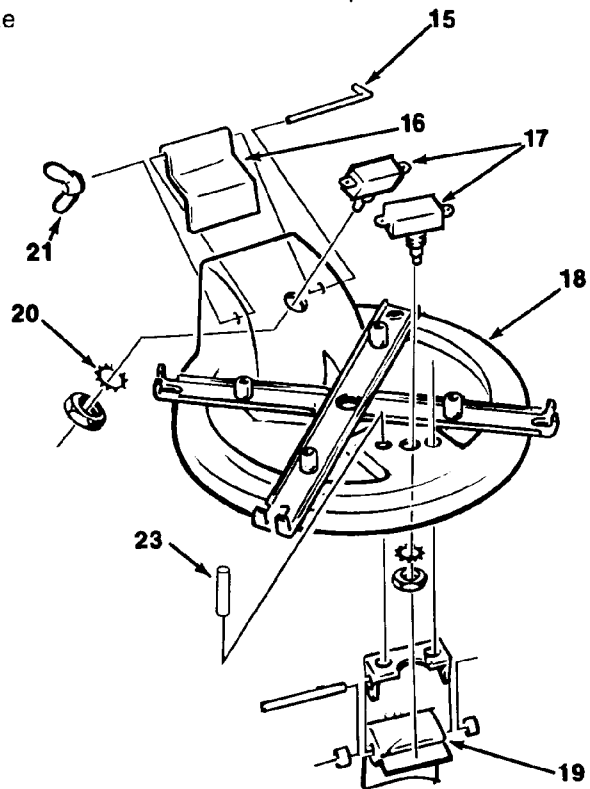
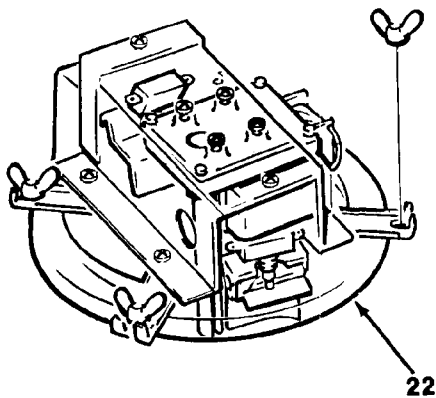
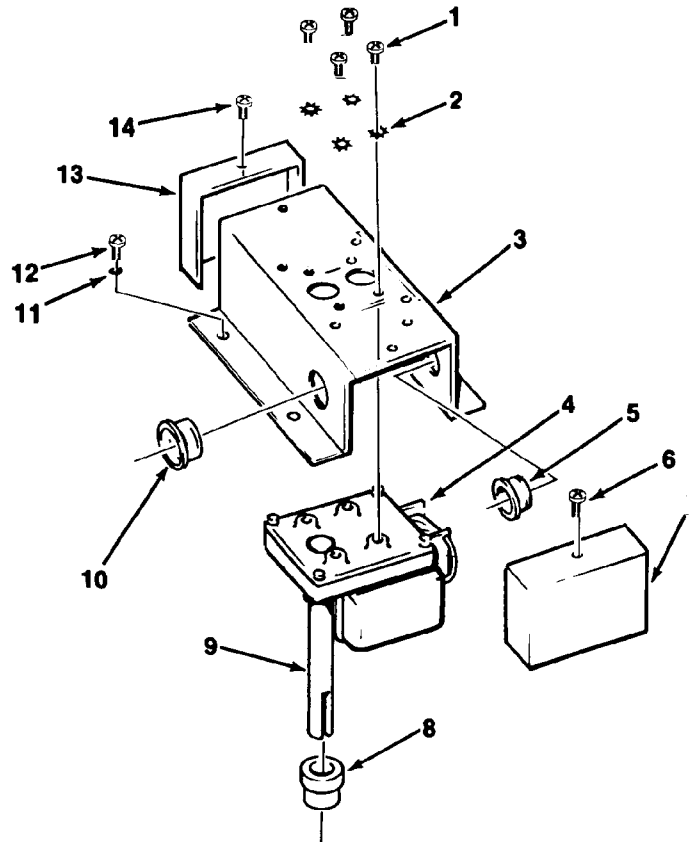

FD4 THE PARTS ILLUSTRATIONS AND PARTS LISTS

POTABLE WATER AND DRAINAGE SYSTEM

ITEM NUMBER	PART NUMBER	DESCRIPTION
1	A26440-001	Inner Bin
2	A26445-001	Inner Bin, Bottom
3	A26435-001	Hub Assembly
4	03-1409-18	Washer, Fiber
5	No Number	Tube
6	A26447-001	Bin Fab Assembly, Foam
7	16-0163-00	Coupling
8	03-1394-00	Pal Nut
9	No Number	Lockwasher
10	12-1434-04	Water Valve
11	No Number	Tube Assembly
12	16-0643-00	Half Union
13	03-0571-00	Screw
14	No Number	Bracket
15	03-1409-21	Washer, Rubber
16	11-0296-00	Pressure Control
17	A21429-000	Sink Assembly
18	13-0674-08	Tube, 12" (Order per ft.)
19	02-1338-00	Clamps
20	02-1338-00	Clamps
21	No Number	Tee, Fab Assembly
22	02-1338-00	Clamps
23	13-0079-03	Tube (Overflow to Drain) 12" (Order per ft.)
24	13-0674-09	Tube (To Freezer)7" (Order per ft.)
25	02-0535-00	Clamp
26	02-0694-00	Clamp
27	02-2217-01	Reservoir Assembly
28	02-1473-00	Grate
29	A21419-000	Reservoir BKT.
30	02-2217-02	Float and Arm Assembly
31	No Number	Inlet Fitting

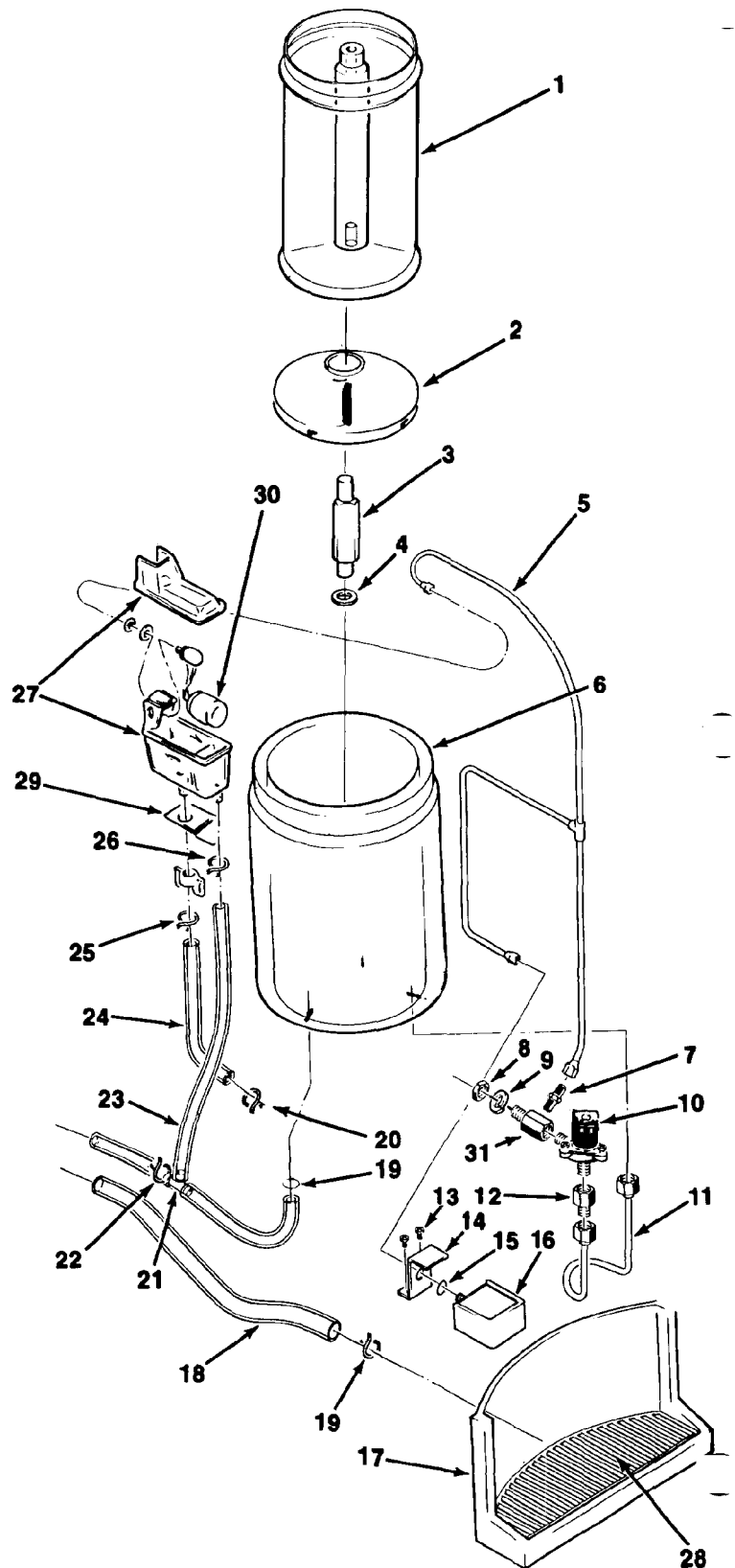

FD4 THE PARTS ILLUSTRATIONS AND PARTS LISTS

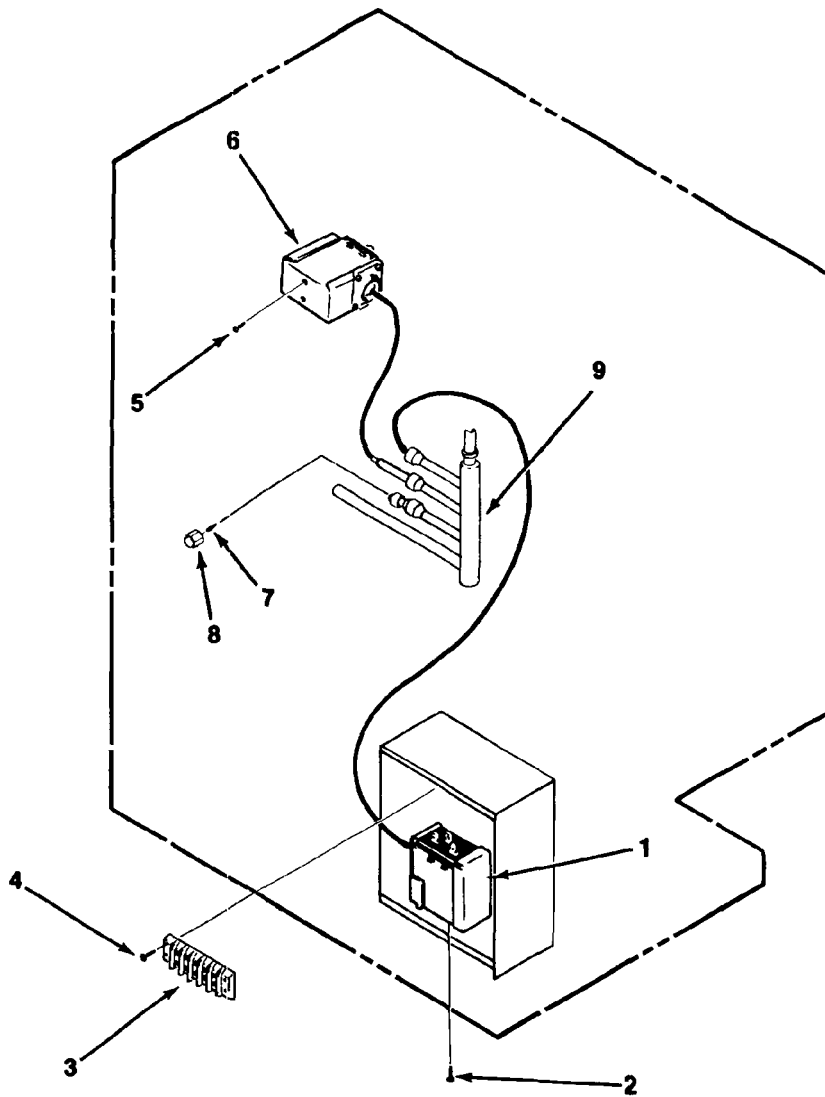

CONTROL BOX ASSEMBLY

ITEM NUMBER	PART NUMBER	DESCRIPTION
1	11-0402-01	Auger Delay Control
2	03-1403-02	Screw
3	12-0813-03	Terminal Block
4	03-1403-20	Screw
5	03-1403-02	Screw
6	11-0420-01	Lo Pressure Control
7	16-0560-00	Valve Core
8	16-0563-00	Valve Cap
9	16-0673-18	Process Header Low Side

FD4 THE PARTS ILLUSTRATIONS AND PARTS LISTS

SINK EXTENSION KIT

A conversion for the FD4 dispenser to increase the distance between the discharge spout and the sink to twelve inches and to provide a faster sink drainage.

KDE1 — PAINTED

KDE1-SS — STAINLESS STEEL

ITEM NUMBER	PART NUMBER	DESCRIPTION
1	02-1828-00	Splash Plate
2	02-1701-00	Drain Grill
3	02-1699-00	Sink Assembly
4	A21538-000 A21538-001	Base Painted Base Stainless Steel

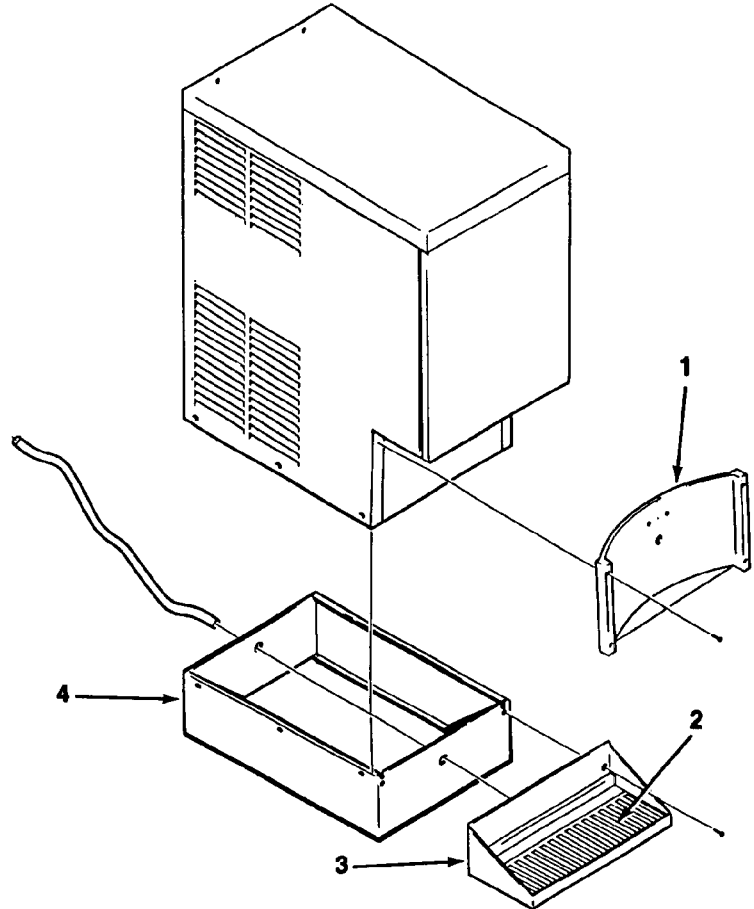

KWB1 WALL MOUNT KIT

An option to attach an FD4 to the wall.

COMPONENT DESCRIPTION

**KWB1 WALL MOUNT KIT
COMPONENT DESCRIPTION**

KIT CONTENTS

1. **Top Case Hanger Bracket.** Attach to inside of frame of the dispenser.
2. **Top Wall Bracket.** Mounts to wall and engages top case hanger bracket to support dispenser.
3. **Bottom Wall Bracket.** Mounts to wall and supports bottom of dispenser.
4. **Bottom Fittings Cover.** Fastened to bottom wall bracket to conceal electrical and plumbing fittings from view.

(No Service Parts)

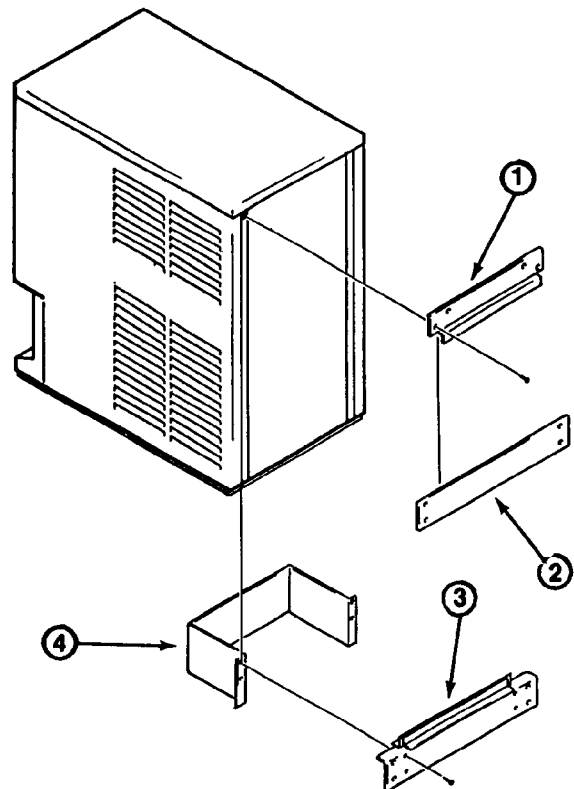

FD4 THE PARTS ILLUSTRATIONS AND PARTS LISTS

USE COPPER CONDUCTORS ONLY

CONTROLS SHOWN IN THE ICE MAKING MODE
WITH ALL DISPENSING SYSTEMS IN OPERATION

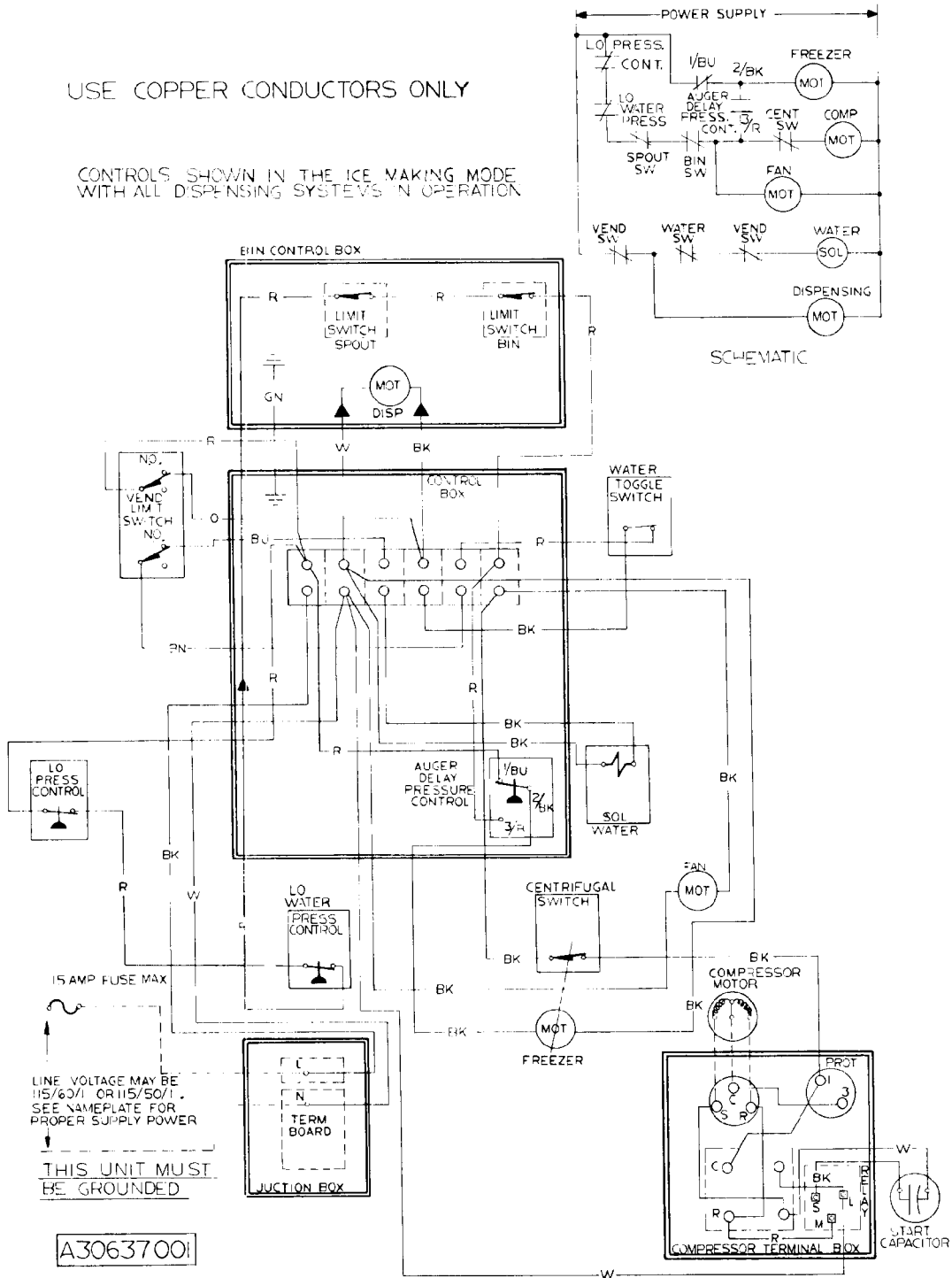

Wiring Diagram FD4A-1D (115/60/1)